

High Fidelity CPR Mannequin



Team Members: Michael Boyle Nihar Dharamsey Simon Healey Nihar Naik Andrew Stanley

Advisor: Dr. Katherine J. Kuchenbecker

Sponsor: Matthew Maltese

Introduction

The purpose of this project was to design and build a high fidelity chest mannequin for cardiopulmonary resuscitation (CPR). A variety of mannequins already exist to simulate a multitude of human-like characteristics, including breathing, vomiting, sweating, pupil dilation, and proper response to the administration of medicine. Of these mannequins, however, none (including the most complex mannequins and simulators) have chest characteristics that accurately recreate the feel of the human chest. A human chest exhibits non-linear forces and significant hysteresis during CPR, and traditional spring based mannequins do not exhibit these features.

The project's primary goal was to add hysteresis to the CPR mannequin. By incorporating data from real CPR administrations, the team developed a model that it then used to provide the appropriate amount of damping force so that any CPR performed on the high fidelity mannequin would feel more realistic than if it were performed on a traditional CPR mannequin. When combined with a feedback system that informs users whether or not CPR is being performed correctly, the high fidelity mannequin serves as a more effective training tool for those learning or improving their CPR.

Modeling the Human Chest

As shown in the data below, collected from real administrations of CPR at the Children's Hospital of Philadelphia, the human chest deflects fairly linearly with increasing force during the compression. The force-deflection characteristics of a simple spring-mass system accurately mimics this behavior. During the rebound, however, the human chest rebounds with less force than was required to compress it, modeled more accurately by adding a damper system, with the coefficients calculated from a least-squares fit to the real data.

Real Data from Human Chest

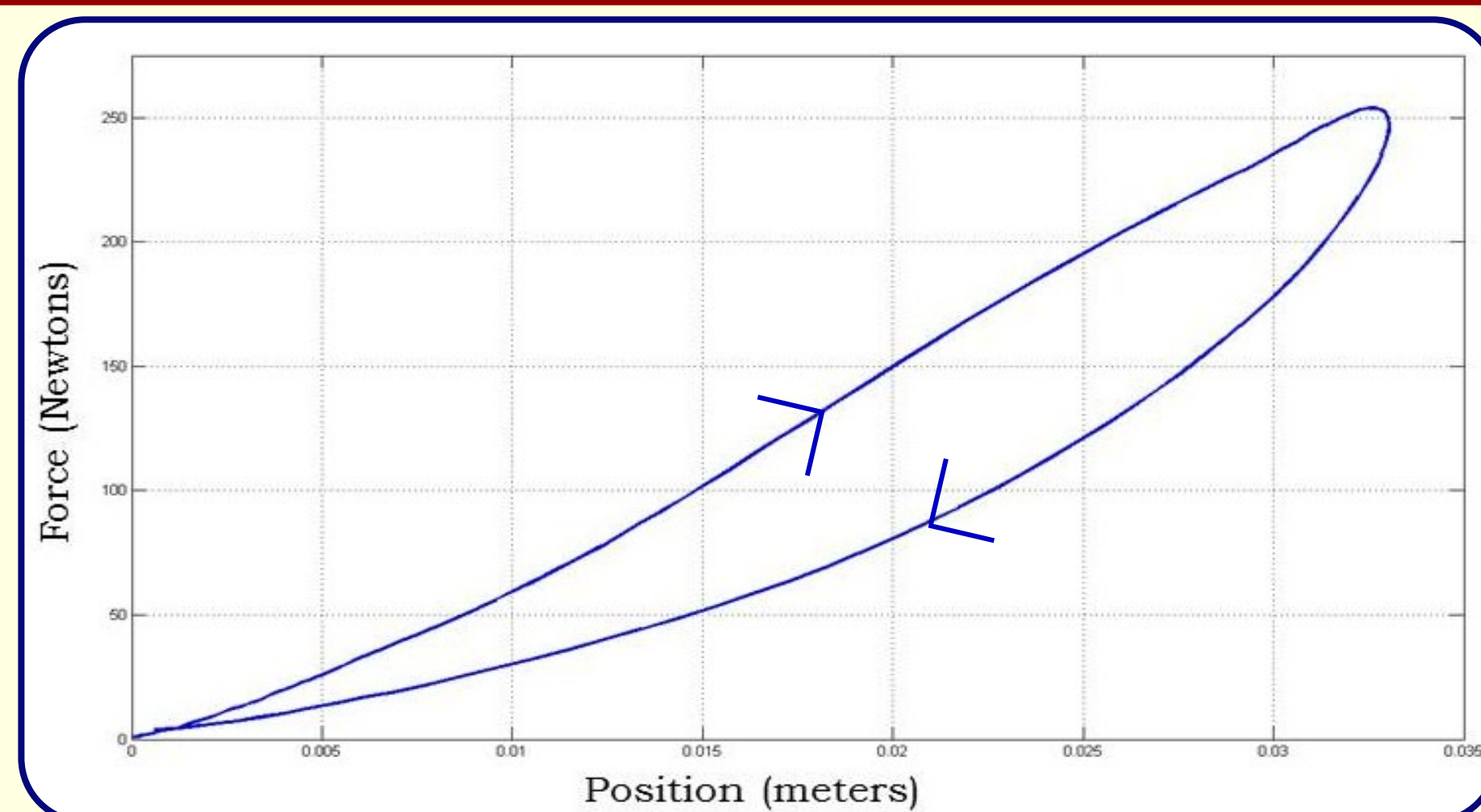

The plot below compares the real data to both the spring force and the force from the one-way damping model. Force residuals are shown underneath, highlighting the inadequacy of modeling the rebound of the chest with only a spring.

Modeling One Way Damping

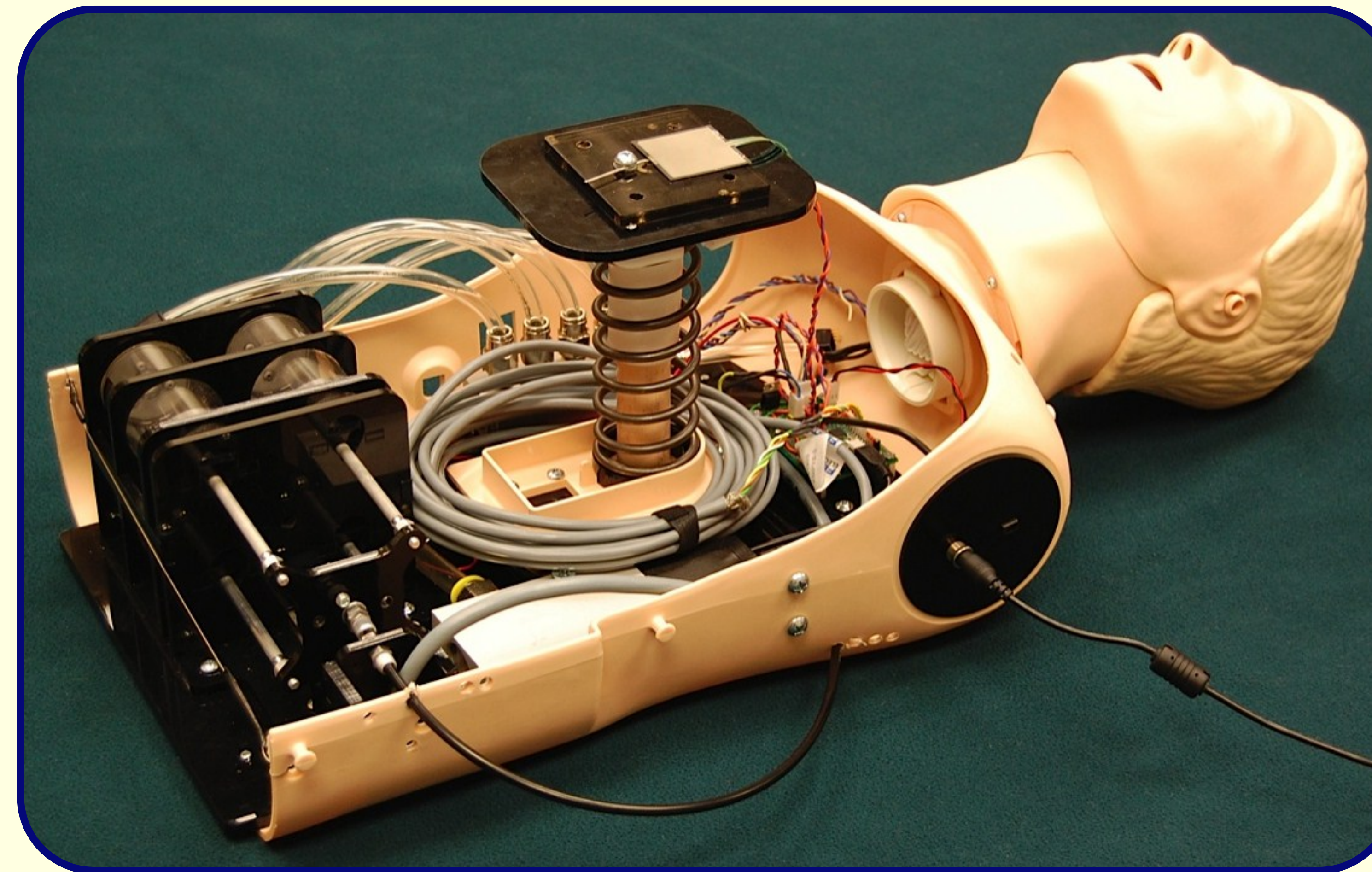
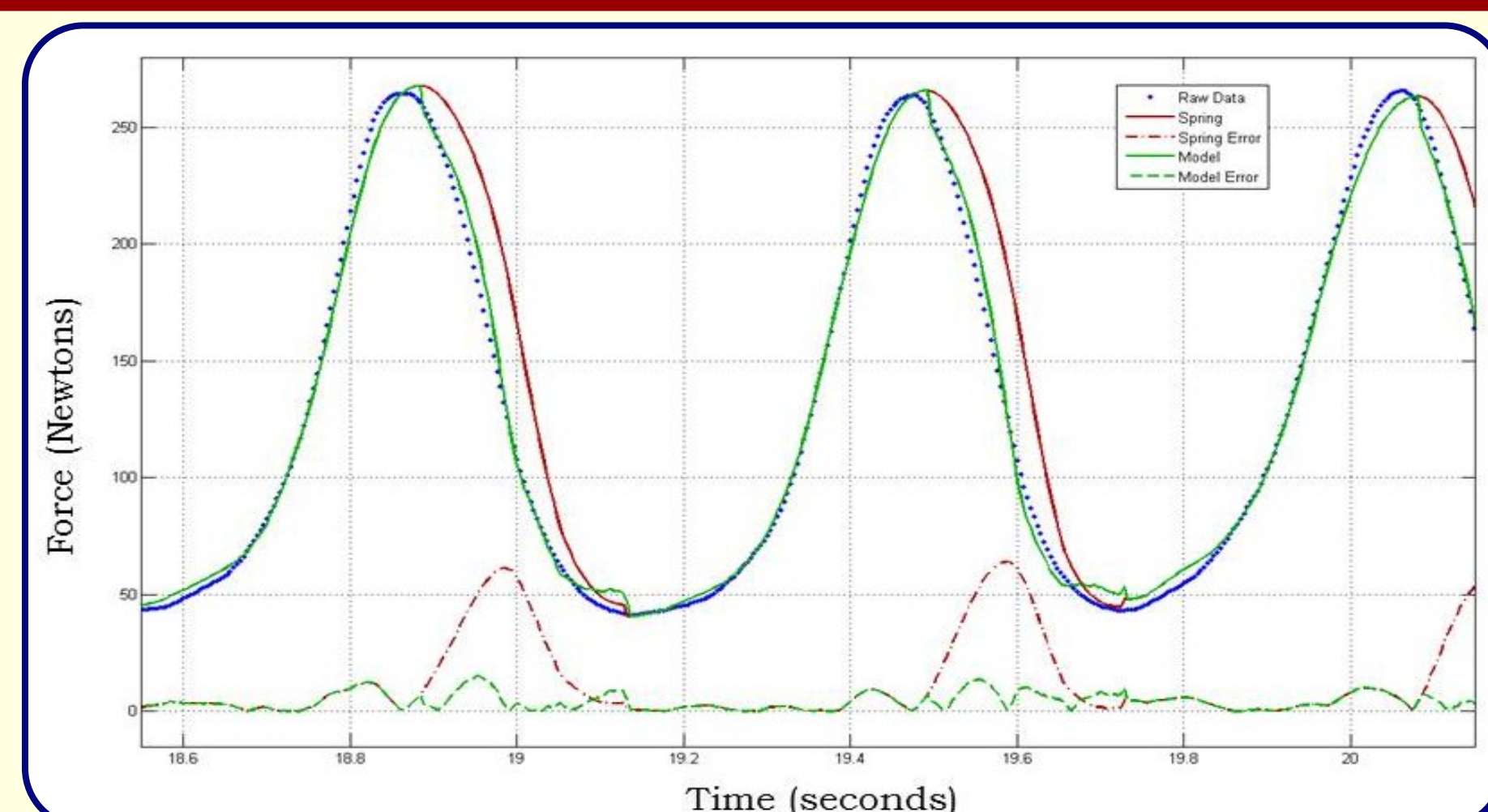

Controls

To achieve the one-way damping characteristics of the human chest, a microcontroller sends varying voltages to adjust the orifice of a programmable valve while the pistons of the dashpots move up and down with the compressions. The equations below provide the feed-forward term and plant dynamics for the block diagram used to simulate the system, and a PD compensator allows for more accurate tracking of the desired force output from the model.

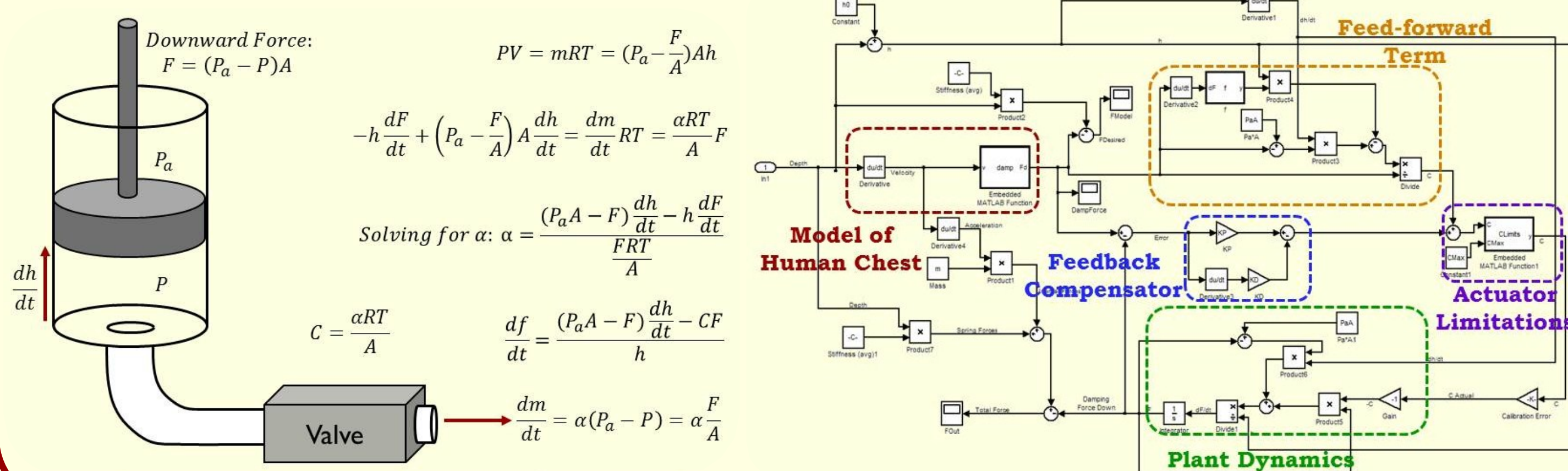

Graphical User Interface

The Graphical User Interface (GUI) provides real time feedback to users about the quality of CPR being performed. The GUI plots pressure, time, compression depth, system force, and valve voltage (left plot). After a training session is completed, the GUI analysis displays information to the user whether the compression depth, compression frequency, and release force have been achieved (right plot).

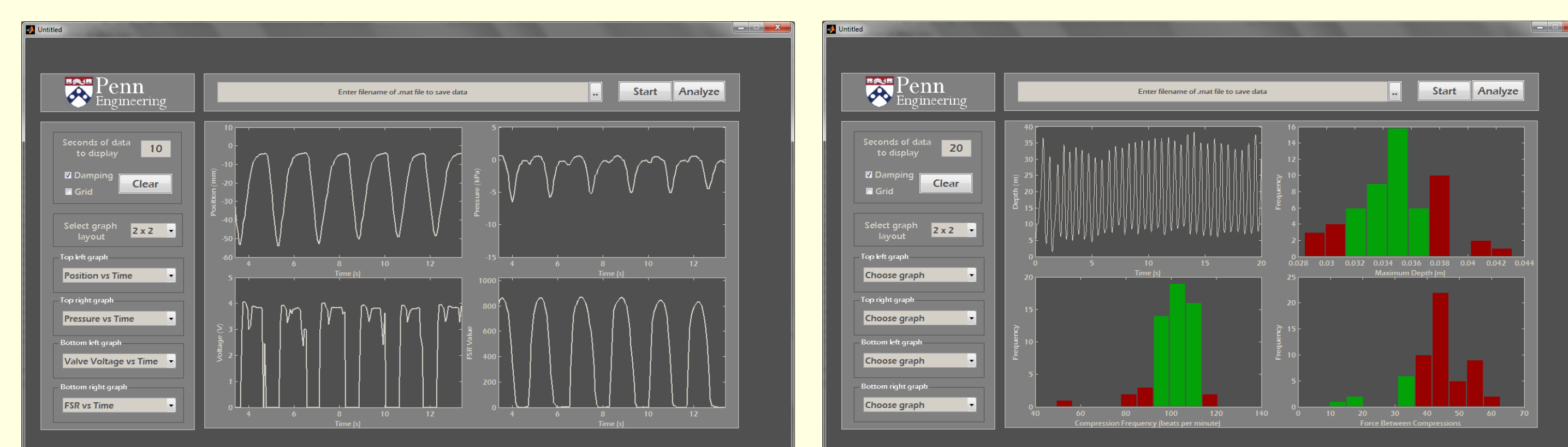

Results

Quantitative Performance

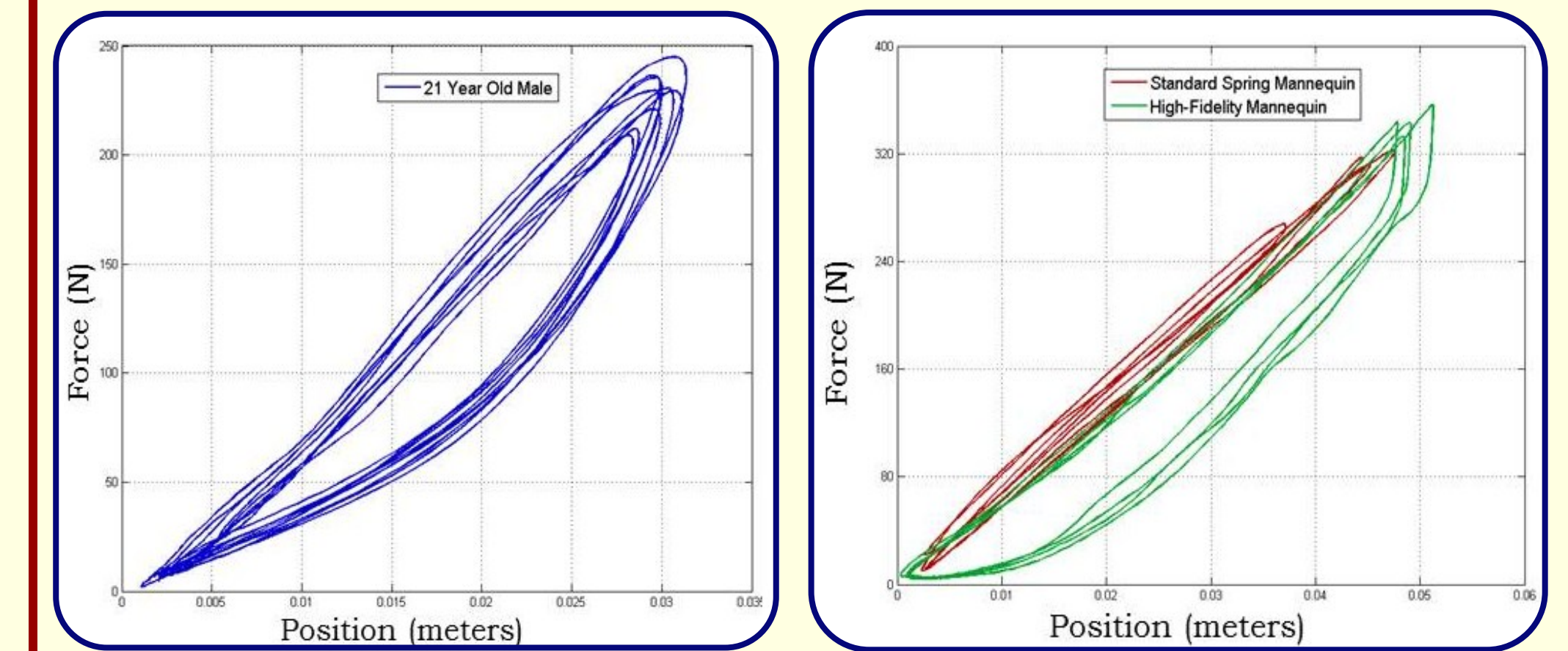

The plot on the left shows the actual force-displacement curve from real administration of CPR on a human. The plot on the right shows the force-displacement curve for a traditional CPR mannequin (spring only in red) and the curve for the team's high fidelity mannequin (spring and damping in green). It is clearly evident that the high fidelity mannequin more accurately recreates the feel of the human body (to the CPR administrator). This can be seen by the fact that the green plot (the high fidelity mannequin) more closely resembles the blue plot (actual data) than the red plot (standard spring mannequin). Though the magnitude of the force varies slightly (as can be seen by the different Force axis scales), this can be accounted for by simply installing a stiffer spring in the high fidelity mannequin.

Qualitative Performance

"A very realistic model... The feel of the downstroke and upstroke of the chest compressions are very similar to a human now, and much better than on the standard spring mannequin."

-Dr. Vinay Nadkarni, Children's Hospital of Philadelphia

Final Prototype Components

Spring provides a spring force throughout the compression cycle. Springs of different stiffness can easily be installed to simulate chests of various stiffness.

AirPots provide the damping force required in the mannequin. By controlling the opening of the valve, the pressure changes consequently changing the damping force.

Valve opens and closes based on the voltage supplied to it by the microcontroller. The supplied voltage varies the cross-sectional area of the valve linearly with the voltage applied providing the necessary damping needed at a point in the compression cycle.

Push-Pull Cable converts the vertical motion of the chest into horizontal motion

Microcontroller performs most of the computations required by our CPR mannequin. Using the position of the slide potentiometer and the pressure inside the pneumatic system, the microcontroller will output the necessary voltage to open the valve the correct amount.

Pressure Transducer determines the damping force exerted by the AirPots by measuring the pressure difference between the AirPots and the atmosphere.

Slide Potentiometer provides information to the microcontroller about where in the compression cycle the mannequin is so that the proper damping force can be applied at the appropriate point in the CPR cycle.

Force Sensing Resistor (FSR) measures the force applied and sends that measurement to the computer, allowing the computer to provide feedback to the user regarding the quality of CPR being performed. The FSR detects if the CPR performer removes all weight from the chest after each compression cycle to allow for the chest to expand completely as recommended by current CPR guidelines.

Manifold connects the different aspects of the pneumatic system.